

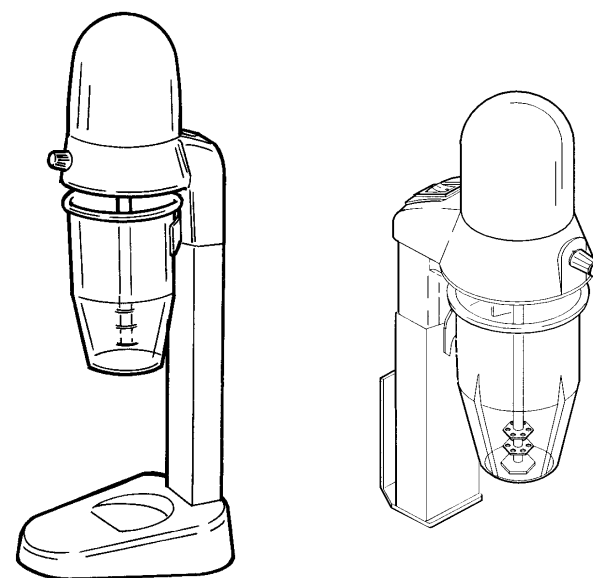

**SERVICE CENTER  
AUTHORIZED DEALER**

## **OPERATING AND MAINTENANCE MANUAL**



Ed. 05/2014

# **Milkshaker**

## INTRODUCTION

- *This manual is meant to provide customers with any information on the machine and its specifications and the necessary operating and maintenance instructions in order to guarantee the best possible use of the machine and preserve its efficiency in time.*
- *This manual is to be handed over to qualified personnel well informed about the use of the machine and its periodical maintenance.*

## TABLE OF CONTENTS

<b>CHAP. 1 - INFORMATION ON THE MACHINE</b>	pag. 4
1.1 - GENERAL PRECAUTIONS	
1.2 - SAFETY SYSTEMS INSTALLED IN THE MACHINE	
1.2.1 - mechanical safety system	
1.2.2 - electrical safety system	
1.3 - MACHINE DESCRIPTION	
1.3.1 - general description	
1.3.2 - construction features	
1.3.3 - machine configuration	
<b>CHAP. 2 - TECHNICAL DATA</b>	pag. 6
2.1 - OVERALL DIMENSIONS, WEIGHT, CHARACTERISTICS	
<b>CHAP. 3 - MACHINE RECEIPT</b>	pag. 7
3.1 - MACHINE SHIPMENT	
3.2 - CHECK ON THE PACKAGE UPON ARRIVAL	
3.3 - PACKAGING DISPOSAL	
<b>CHAP. 4 - INSTALLATION</b>	pag. 8
4.1 - MACHINE SET-UP	
4.2 - ELECTRIC CONNECTION (equipped with single-phase motor)	
4.2.1 - Shaker equipped with single-phase motor	
4.3 - ELECTRIC DIAGRAMS	
4.4 - OPERATION CHECKS	
<b>CHAP. 5 - USE OF THE MACHINE</b>	pag. 9
5.1 - CONTROLS	
5.2 - LOADING AND SHAKING OF FOODSTUFFS	
<b>CHAP. 6 - ORDINARY CLEANING</b>	pag. 10
6.1 - GENERAL FEATURES	
6.2 - ORDINARY CLEANING	

## CHAP. 7 - MAINTENANCE

### 7.1 - GENERAL FEATURES

Before starting any maintenance operation the power supply cord plug should be disconnected from the socket to isolate the shaker from the rest of the system.

### 7.2 - POWER SUPPLY CORD

Periodically check whether the power supply cord is worn-out and, if so, please call the “SERVICE CENTRE” to have it replaced.

## CHAP. 8 - MACHINE DISPOSAL

### 8.1 - PUTTING THE MACHINE OUT OF SERVICE

If for some reason, you decide to put the machine out of service, make sure nobody can use it: disconnect it from mains and eliminate the electrical connections

### 8.2 - WEEE Waste of Electric and Electronic Equipment



*Directive 2002/95/EC, 2002/96/EC and 2003/108/EC on the restriction of the use of certain hazardous substances in electrical and electronic equipment, and waste electrical and electronic equipment .*

*This symbol, crossed out wheeled bin, on the product or on its packaging indicates that this product must not be disposed of with your other household waste.*

*Separate waste collection of this appliance is organised and managed by the manufacturer. It is the user's responsibility to contact the manufacturer and follow the waste treatment system the manufacturer has adopted for separate waste collection.*

*The separate collection and recycling of your waste equipment at the time of disposal will help to conserve natural resources and ensure that it is recycled in a manner that protects human health and the environment.*

## 5.2 - LOADING AND SHAKING OF PRODUCTS

**N.B.:** Products to be shaken must be loaded into the beaker only when the switch has been set to “0”

1. Once the product have been loaded onto the beaker, place it on the supports cautiously.
2. Make sure that the beaker is stable and properly placed.
3. Push the switch to the “I” operating position.
4. If using a Shaker VV model, adjust the speed of the whisks by means of the speed dial knob (gradually changing the speed from the minimum to the maximum allowed).
5. Do not operate the shaker while it is empty.
6. Once foodstuffs have been shaken, set the speed dial knob to the minimum speed and switch off the machine by setting the switch to the “0” stop position; then remove the beaker cautiously.
7. The operating period must be limited to 10 minutes to prevent the motor from overheating. After a rest of about 10 minutes the shaker can be used again.

## CHAP. 6 - ORDINARY CLEANING

Before starting this chapter a clarification is necessary. Shaker professional shakers are provided with the prescribed electrical and mechanical safety systems during functioning, cleaning and maintenance operations.

However **RESIDUAL RISKS** cannot be completely ruled out; they concern the possibility of contusions due to accidental contacts with the whisk and other cutting parts during cleaning and maintenance operations.

### 6.1 - GENERAL FEATURES

Before carrying out any cleaning operation it is necessary to:

- a) disconnect the power supply plug from the socket to isolate the shaker from the rest of the system;
- b) set the switch to “0” position;

The shaker should not be cleaned with water-cleaners and high pressure jets of water.

Tools, brushes and other devices likely to damage the machine surface should not be used.

### 6.2 - CLEANING

Cleanse frequently the glass and wash it in the washing machine with mild soap if you do not use it for more than 2 hours or at least once a day.

Clean the shaft and the whisk (see ref. n. 8-9, page 5, picture nr. 1) every time that the machine is not in use for more than 2 hours or at least once a day.

Fill the glass with mild soap solution and make the milkshaker work for about half minute. Change water without adding soap and make the milkshaker work again for two other cycles of 10 seconds each. Clean motor housing by washing with mild soap and water using a soft cloth or sponge.

### 6.3 - SANITIZING

Fill the glass with “Milton” or similar feature (with minimum of 50 ppm of chlorine) and make the milkshaker work for about ten seconds.

### 6.3 - SANITIZING

## CAP. 7 - MAINTENANCE

### 7.1 - GENERAL FEATURES

### 7.2 - POWER SUPPLY CORD

pag. 11

## CHAP. 8 - MACHINE DISPOSAL

### 8.1 - PUTTING THE MACHINE OUT OF SERVICE

### 8.2 - WEEE Waste of Electric and Electronic Equipment

pag. 11

## CAP. 1 - INFORMATION ON THE MACHINE

### 1.1 - GENERAL PRECAUTIONS

- The Shaker must be operated only by qualified personnel who must be informed about the safety measures described in this manual.
- In case of personnel turn-over, training is to be provided in advance.
- Although the shaker is equipped with safety devices in the dangerous points, it is recommended not to touch the moving components.
- Before starting cleaning and maintenance, disconnect the shaker plug from the supply socket.
- Carefully assess the residual risks when protection devices are removed to carry out cleaning and maintenance.
- Cleaning and maintenance require great concentration.
- A regular control of electric supply cord is absolutely necessary; a worn-out or damaged cord can expose users to serious electric shock hazard.
- If shaker shows malfunctions, it is recommended not to use it and to abstain from trying to repair it; please call the "Service Centre".
- Do not use the shaker for frozen products and any liquid products other than foodstuffs.
- **The manufacturer is not liable in the following cases:**
  - ⇒ if the slicer has been tampered by non-authorized personnel;
  - ⇒ if some parts have been substituted by non original spare parts;
  - ⇒ if the instructions contained in this manual are not followed accurately;
  - ⇒ if the slicer is not cleaned and oiled with the right products.

### 1.2 - SAFETY SYSTEMS INSTALLED IN THE MACHINE

#### 1.2.1 - mechanical safety system

The shaker mechanical safety system complies with EC directives **2006/42**. The safety system includes: beaker ( see 1.3.3 shaker components).

#### 1.2.2 - electrical safety system

The shaker is equipped with a micro-switch which stops the machine if the user inadvertently removes the beaker; the micro automatically restarts the shaker as soon as the beaker has been reinstalled.

### 1.3 - MACHINE DESCRIPTION

#### 1.3.1 - general description

Our firm has designed and manufactured the Shaker line of shakers in order to guarantee:

- the highest degree of safety in functioning, cleaning and maintenance;
- the highest hygienic standards due to an accurate choice of materials and a smooth design of the shaker components which come into contact with foodstuffs in order to obtain easy cleaning and disassembly;
- possibility to operate with alternate switch-on and switch-off periods of 10

### 4.3 - electric circuit diagram

FIG. n°6 - 230V single-phase electric diagram

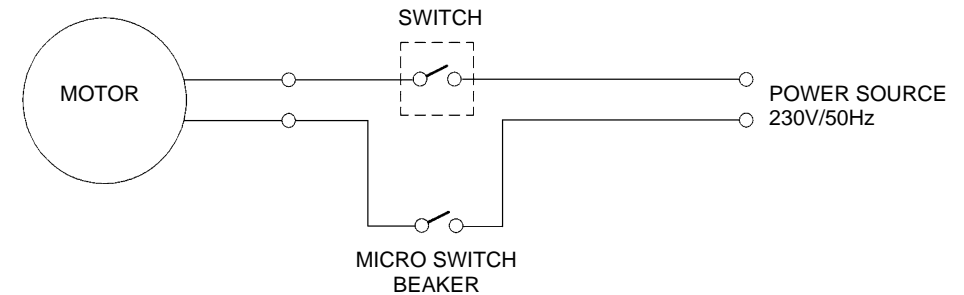

### 4.4 - OPERATION CHECKS

Before testing the shaker check that the beaker is blocked and then try operation as indicated below:

1. push the switch to the "I" operating position and to the "0" stopping position (see FIG. n°7);
2. check the rotation of the whisks when the beaker is properly placed by setting the switch to the "I" and "0" position alternatively;
3. with regard to the Shaker VV shaker, check the proper functioning of the motor and the speed dial knob;
4. check that the shaker stops functioning when the beaker is removed.

## CAP. 5 - OPERATING OF THE SHAKER

### 5.1 - CONTROLS

The switch-on button is placed on the upper part of the stem; in the Shaker VV model the speed dial knob is on the front side of the head (see FIG. n°7).

1. The switch can be adjusted in two positions:
  - a) "I" start position;
  - b) "0" stop position.
2. Speed dial knob adjusting the speed of the whisks.

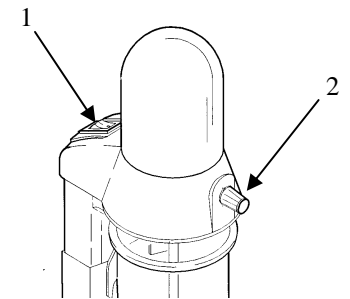
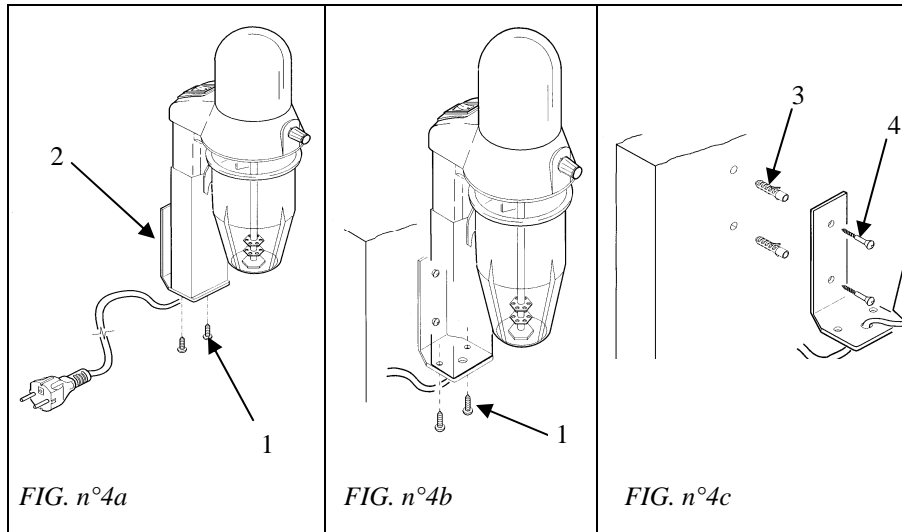

FIG. n°7 - Location of controls

## INSTALLATION OF SHAKER P



### 4.2 - ELECTRIC CONNECTIONS

#### 4.2.1 - shaker equipped with single-phase motor

The shaker is equipped with a power supply cord (section of 31sq mm and length of 1.5m) and a "SHUKO" plug.

Connect the shaker at 230 V - 50 Hz by interposing a differential-magnetothermal switch of 10A,  $\Delta I = 0,03A$ .

Check that earthing is fully operational. Also check that features on the reference plate - serial number (FIG. n°5) correspond to the features shown in the consignment and delivery note.

Mod.	_____	Watt.	_____
Matr.	_____	A.	_____
	H.p. _____	Hz.	_____
○	~ Volts. _____	Kg.	○ _____
Anno	_____		

FIG. n°5 - Reference plate - serial number

- minutes each;
- maximum efficiency given by the single three-whisk system;
- solidity and stability of components;
- the lowest noise level;
- great handiness.

### 1.3.2 - construction features

The shaker is made of chromium-plated ABS, an aluminium alloy (Peraluman Mg 5) treated by anodic oxidation (an electrolytic process increasing the thickness and stabilising the oxide film of some metals and alloys. This process is used especially for aluminium and its alloys). The anodic oxidation guarantees hygienic contact with foodstuffs and resistance to acids, salts and oxidation.

### 1.3.3 - machine configuration

FIG. n°1 - General view of the shaker

#### Shaker

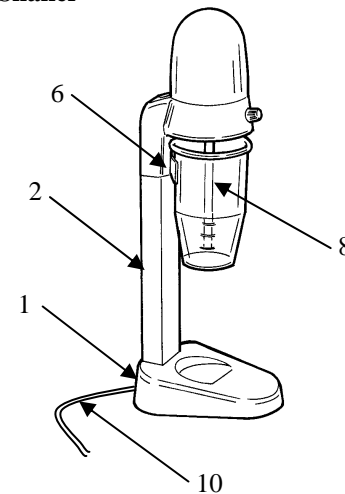

#### Shaker P

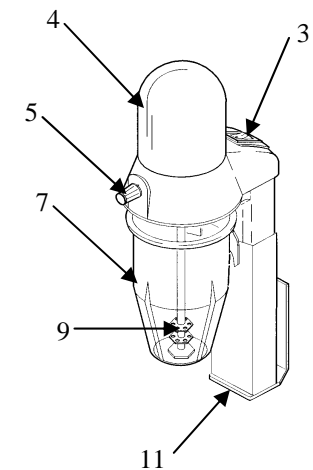

### LEGEND:

1	Base	7	Beaker
2	Stem	8	Shaft
3	Switch ON/OFF	9	Whisks
4	Head	10	Power supply cord
5	Speed dial knob	11	Shaker wall holder
6	Beaker support		

## CHAP. 2 - TECHNICAL DATA

### 2.1 - OVERALL DIMENSIONS, WEIGHT, CHARACTERISTICS

FIG. n°2 - Drawing of the overall dimensions

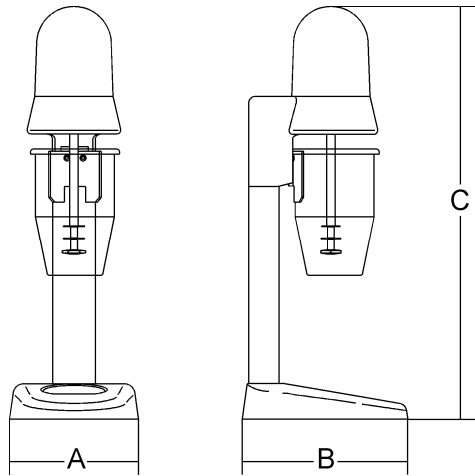

TAB. n°1 - DIMENSIONS AND TECHNICAL CHARACTERISTICS

	Power	Power source	Motor	Jug capacity	AxBxC	Net weight	Noise Level
	Watt/Hp		r.p.m.	lt.	mm	kg	dB
Frappè 1	100/0,14	230V 50/60Hz	14.000	0,55	150x195x485	2,5	75
Frappè 2	100/0,14 x 2	230V 50/60Hz	14.000	0,55 x 2	300x195x485	5	75
Frappè P	100/0,14	230V 50/60Hz	14.000	0,55	110x150x360	2	75
Frappè 1 VV	100/0,14	230V 50/60Hz	4.000 ÷ 14.000	0,55	150x195x485	2,5	75
Frappè 2 VV	100/0,14 x 2	230V 50/60Hz	4.000 ÷ 14.000	0,55 x 2	300x195x485	5	75
Frappè 1 900cc	120/0,16	230V 50/60Hz	14.000	0,9	150x195x530	2,7	75
Frappè 2 900cc	120/0,16 x 2	230V 50/60Hz	14.000	0,9 x 2	150x195x530	5,2	75
Frappè 1 VV 900cc	120/0,16	230V 50/60Hz	4.000 ÷ 14.000	0,9	300x195x530	2,7	75
Frappè 2 VV 900cc	120/0,16 x 2	230V 50/60Hz	4.000 ÷ 14.000	0,9 x 2	300x195x530	5,2	75

**WARNING:** Electrical features of the shaker are shown on the reference plate placed under the base of the machine; before connecting the shaker to the electric system see **4.2. - Electric connections.**

## CHAP. 3 - MACHINE RECEIPT

### 3.1 - MACHINE SHIPMENT (see Fig. n°3)

Shakers are accurately packed and then dispatched from our warehouses; the package includes:

- a strong cardboard box;
- the shaker;
- this manual.

Moreover the box contains the machine packaging material made of either cardboard filling grafts or polyurethane.

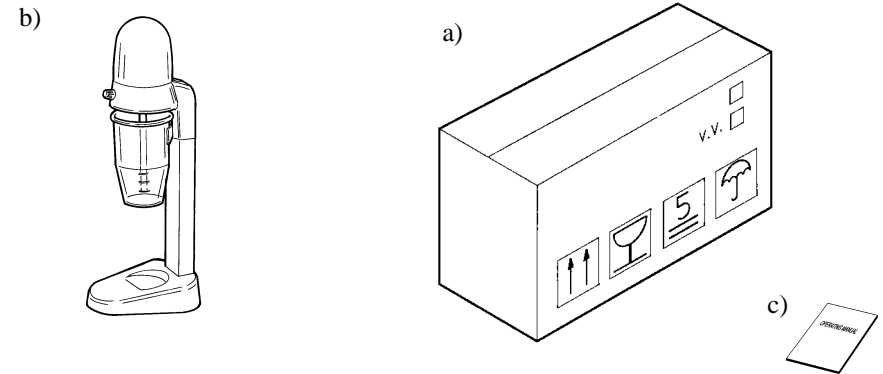

FIG. n° 3 - Description of the package

### 3.2 - CHECK ON THE PACKAGE UPON ARRIVAL

If no external damage is evident on the package upon its arrival, open it and check that all the components are inside (see FIG. n° 3). If the package has suffered from rough handling, bumps or crashes, the carrier must be informed about any damage; moreover a detailed report on the extent of the damage caused to the machine must be filed within three days from the delivery date shown in the shipping documents.

### 3.3 - PACKAGING DISPOSAL

The components of the packaging (cardboard box, pallets, plastic straps and polyurethane foam) may be considered as urban solid waste; therefore they can be easily disposed of. If the shaker is to be installed in countries where specific regulations are in force, packaging should be disposed of in compliance with these ones.